

NOUVEAUTÉ
2013

R LIFT 900

| HOTTE DE PLAN |



Hotte éteinte



Hotte en fonctionnement

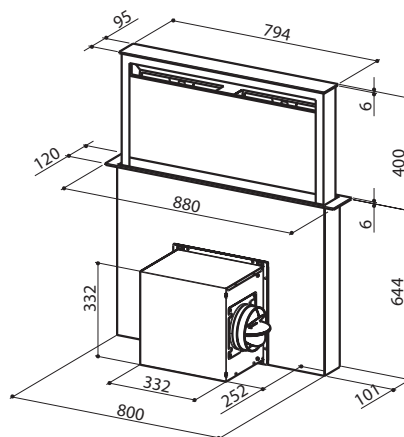

SPÉCIFICITÉS TECHNIQUES

Moteur Energy 275 W - 500 Pa
Sensitive (4 vitesses + intensive)
LED de 10 W
Filtre métalliques

R LIFT 900

	Mini	Moyen	Maxi	Intensif
Débit (m ³ /h)	265	500	565	725
Pression (Pa)	235	410	430	480
Bruit (dB(A))	49	63	66	71
Watt (W)	70	160	190	275

Installation en évacuation extérieure ou en recyclage.

Ouverture motorisée de la hotte lors de la mise en fonctionnement
Prévoir un tuyau Ø 150 mm

ESS R LIFT 900

version motorisée

900

inox / verre noir



5057000

1999,00 TTC
1671,40 HT

ACCESSOIRES (EN OPTION)

5401009
Télécommande

5403014
Filtre charbon

LES ESSENTIELLES HOTTES DE PLAN

Roblin